



Addendum No. 1

To: Prospective Bidders

From: Will Mastin
City of Mobile Architectural Engineering Department

Re: Laun Park – Splash Pad Improvements

Project #PR-079-22

Date: July 15, 2024

This Addendum forms a part of, and modifies, the Request for Bids, for the above referenced project, dated June 24, 2024. Acknowledge the receipt of this Addendum No. 1 in the space provided on the Bid Form. Failure to do so may subject Bidder to disqualification.

General:

Clarifications:

- Item 1. Pre-Bid Meeting Agenda and Pre-Bid Meeting Acknowledgment Roster, dated July 3, 2024 are attached and form part of Addendum No. 1. Revisions to the Pre-Bid Agenda are indicated with a strike-through for deletions and ***bold italic*** typeface for additions.
- Item 2. RFI # 1 response regarding electrical service and voltage requirements is included in this addenda. See Attached Electrical Schedule and Schematics.
- Item 3. A courtesy on site meeting for all interested bidders to review existing electrical service panel inside of utility building shall be held Tuesday July 16, 2024 at 8 am at the site to review existing electrical panel.

Item 4: The bid Due Date has been changed to July 24, 2024. All other bidding instructions to remain the same.

Request for Bids:

Drawings:

Item #1: Electrical Schedule and Schematics attached to this addendum.

RFI's:

Item 1. - RFI #1 response

Question: "Do you have any requirements on what size and voltage feed is required for the Splashpad controller?"

Answer: See schematic attached below for electrical demands provided by the equipment company. See Item #3, Clarifications, for on site meeting date and time. For additional information on meeting contact project manager Will Mastin. (will.mastin@cityofmobile.org) or by calling (251) 406-2678.

END OF ADDENDUM NO. 1

**PRE-BID CONFERENCE AGENDA
PROJECT
FOR
CITY OF MOBILE PARK IMPROVEMENTS
LAUN PARK – NEW SPLASH PAD
5401 WINDMILL DRIVE, MOBILE ALABAMA
CITY OF MOBILE PROJECT # PR-079-22
JULY 3, 2024 at 9:00 a.m.**

Note: *This Agenda is complimentary, for general use as an outline and for discussion during this meeting. Any errors, omissions, or clarifications shall be communicated to the Engineer for distribution. This Agenda does not attempt to be, nor represent, any recapitulation of Project requirements, and does not change or alter same in any respect; Changes, if any, will only be made by written Addendum.*

1. Welcoming remarks. Reminder to sign in on sheet being circulated

2. Name of Owner – City of Mobile
Project Manager –Shannon McIntyre, Will Mastin

Christian Preus Landscape Architecture personnel:
Christian Preus – Landscape Architect

3. Every General Contractor and every Subcontractor should read and be familiar with all of the “front-end” documents and all of Division 1 of the Project Manual, in addition to the work they are bidding and have to coordinate with.

4. **Bid time, date, place** – are indicated in the Advertisement for Bids; Sealed bids will be received and clocked in until 2:15 pm, Wednesday, the 17th day of July, 2024 ; bidders shall insert sealed Bids into a receptacle, marked “City of Mobile Bids”, located in the elevator lobby outside the office of the City Clerk Office, 9th Floor South Tower, Government Plaza, 205 Government Street, Mobile, Alabama 36602. Bid will be publicly opened and read at 2:30 PM local time, in the Atrium Lobby of Government Plaza.

It is the Contractors responsibility to make sure Bid is received prior to bid time or they will not be accepted.

5. Note that Advertisement and Instructions to Bidders should be read by each bidder. For insurance requirements refer to Invitation & Instructions to Bidders in the Project Manual. A Certificate of Insurance evidencing all the minimum requirements must be provided to and accepted by the City of Mobile prior to commencing on the contract.

6. Contractors shall use the Bid Form included in Project Manual, copies of which are furnished to each bidder with Bid Documents. Bids must include Attachment A to Bid Form (Unit Prices) at Bid time and date.

7. Before submitting a bid for the Work, the bidders shall carefully examine the Bid Documents, visit the site, and satisfy themselves as to the nature and location of the Work, and the general and local conditions,

including weather, the general character of the site and building, the character and extent of existing work within or adjacent to the site and any other work being performed thereon at the time of submission of their bids.

8. Addenda - Minutes of Pre-Bid Meeting, and any pertinent items discussed shall be issued as Addendum following the Pre-Bid Meeting. Any further addenda necessary after the Pre-Bid Meeting will be issued to all plan holders.
9. Clarification will be made only by written Addenda posted on the City of Mobile website. Questions and Clarifications must be submitted in writing 48 hours prior to bid.
10. When the Bid Documents identify three or more sources and the list of sources is not followed by “or approved equal” or similar wording, the bidder’s proposal shall be based upon one of the identified sources, unless the bidder obtains “Pre-bid Approval” of another source. Approval of substitutions, if granted, shall not be effective until published by the Architect in an addendum to the Bid Documents. Requests for substitutions will not be considered 72 hours prior to bid.
11. If there is a conflict, discrepancy, or confusion between the existing conditions, plans and specifications for work, materials or equipment and the Contractor does not receive written clarification from the Architect prior to the opening of bids the Contractor shall include the better quality or greater quantity of work in his/her bid.
12. Bids must be submitted on the Bid Form as contained in the Bid Documents; only one copy is required to be submitted.
13. All information requested of the bidder on the Bid Form must be filled in. The form must be completed by typewriter or hand-printed in ink.
14. Bids shall be accompanied by a Bid Security equal to 5% (percent) of the total bid price, including the allowance if any, but in no event not more than \$10,000.00. Bid Security shall be on the form of a Bid Bond or cashier’s check payable to the City of Mobile. No Bid Security is required on Bids less than \$10,000.00.
15. Bid, with Bid Security, Sales Tax Form C-3A, City of Mobile Subcontracting and Major Supplier Plan and other supporting data specified, shall be contained in a sealed, opaque envelope, approximately 9x12 inches or larger and be marked on the outside with the words "SEALED BID FOR (Laun Park – New Splash Pad) – PROJECT NUMBER: (PR-079-22)".
16. Performance Assurance and Insurance: The bidder to whom award is made shall provide a Performance Bond equal to 100% of the total Contract Amount (including the allowance) and a Labor and Material Bond equal to 100% of the total contract amount (including the allowance). The accepted Bidder shall also provide insurance as required in section 1.20
NO WORK IS TO BE PERFORMED UNTIL PROOF OF COMPLIANCE WITH THE INSURANCE REQUIREMENTS HAS BEEN RECEIVED BY THE CITY OF MOBILE.
17. A valid City of Mobile business license for the duration of the contract period. E-verify Documentation: The Beason-Hammond Taxpayer Protection Act applies to this project. Contractor shall comply with the requirements of this Act and show proof of enrollment in the E-verify program by submitting the electronically generated Federal E-verify document prior to signing of the construction contract. (see

Project Manual)

18. Bids may be delivered in person or by mail if ample time is allowed for delivery.
19. Bids will be opened and read publicly at the time and place indicated in the Advertisement for Bids.
20. Alternates, if any, are listed in the Bid Form in the order in which they shall cumulatively add to from the base bid for determining the lowest bidder.
21. Award of contract by Awarding Authority, ASAP after the opening of bids.
22. Proposals may be rejected if they contain any omissions, alterations of forms, additions not called for, conditional bids, alternate bids unless called for, incomplete bids, erasures, or irregularities of any kind.
23. Completion Time for Project: Base Bid Completion Time: **The Project shall be completed within One Hundred and Twenty (120) calendar days from the date indicated by the Notice to Proceed.** Time begins from date of Official Notice to Proceed
24. At the time the Contractor duly awarded the Bid receives the signed Contract and the Notice to Proceed, he shall submit a Schedule of Work Progress to the Architect which reasonably reflects the amount of time required for each Phase of Work and the deadline by which it can be expected that such phase of the Work shall be completed. This Schedule should accurately reflect the date for Substantial Completion, and take into consideration any reasonable contingencies.
25. The Contractor shall be responsible for all project safety. Neither the Architect nor the Owner will be responsible for the Contractor's safety precautions, means, methods, techniques, sequences, or procedures. Contractor's personnel responsible for safety shall be OSHA certified. Safety barricades (as described in the contract documents) for project, including equipment and storage areas, part of contractors means, methods, techniques, sequences, procedures; cost of any type fencing, barricades, etc. necessary shall be incidental to project.
26. Parking for Contractors and their Subs and workers: Shall be coordinated with the Owner.
27. Traffic Control:
 - Coordinate all construction activities with parties having jurisdiction.
 - Particular attention shall also be paid to vehicular and pedestrian traffic and routing of such during project.
28. Meetings: Owner / Architect / Contractor (OAC) Progress Meeting to be held per project requirements. Pre-Construction Conference will be held once a Contractor has been awarded the project and contract signed.
29. Liquidated Damages: Per Item II Invitation & Instructions to Bidders, 1.24 LIQUIDATED DAMAGES: for non-completion of the work within the time limited agreed upon will be assessed in the amount of actual damages to the Owner but in no event not more than \$250.00 per day.
30. Retainage withheld at 5% of the first 50% of Construction Completed until the amount equals 2.5% of the full contract amount. The final 2.5% of the full contract amount is withheld as retainage until all

close out requirements are met, proof of advertisement, warranties, Consent of Surety and release of liens, etc. By State of Alabama Law, notice of final completion of the contract shall be published in a local newspaper of general circulation.

31. Christian Preus (Project Landscape Architect). Address and telephone numbers: 307 De La Mare Avenue, Fairhope, Alabama, 36532. Phone: (855) 539-5086. E-mail: christian@christianpreus.com
Project Manager: Christian Preus, ASLA
Email: christian@christianpreus.com

32. Closing remarks / questions.

ELECTRICAL NOTES:
 1. OUTLETS ARE GFCI PROTECTED.

ADJUSTABLE-SPEED DRIVE SYSTEMS - MINIMUM SIZE AND AMPACITY
 NFPA 70 NEC: 430.122 CONDUCTORS - MINIMUM SIZE AND AMPACITY
 (A) BRANCH/FEEDER CIRCUIT CONDUCTORS, CIRCUIT CONDUCTORS SUPPLYING POWER CONVERSION EQUIPMENT INCLUDED AS PART OF AN ADJUSTABLE-SPEED DRIVE SYSTEM SHALL HAVE AN AMPACITY NOT LESS THAN 125 PERCENT OF THE RATED INPUT CURRENT TO THE POWER CONVERSION EQUIPMENT.
 (B) OUTPUT CONDUCTORS - THE CONDUCTORS BETWEEN POWER CONVERSION EQUIPMENT AND THE MOTOR SHALL HAVE AN AMPACITY EQUAL TO OR LARGER THAN 125 PERCENT OF THE MOTOR FULL LOAD CURRENT AS DETERMINED BY 430.6(A) or (B).

FEEDER & CONDUIT SCHEDULE				
CIR.	PHASE	CONDUCTORS		REMARKS
		NEUTRAL	GROUND	
1	1 - #14	1 - #14	1/2"	PANEL FEED BY OTHERS
7	INDICATES WIRE AND CONDUIT INSTALLED BY OTHERS			TYPE LFNC-B UL SEALTITE

PANEL SCHEDULE					
230V, 1 PHASE, 3 WIRE, NEMA 3R, 125P, 100A MBR					
CIR.	POLES	TRIP	LOAD	AMPS	DEMAND FACTOR
1	1	15A-GFCI	SERVICE LIGHT	1.0	1.3
2	1	20A-GFCI	RAINDROP TIMER	16.0	20.0
TOTAL LOAD				17.0	21.3

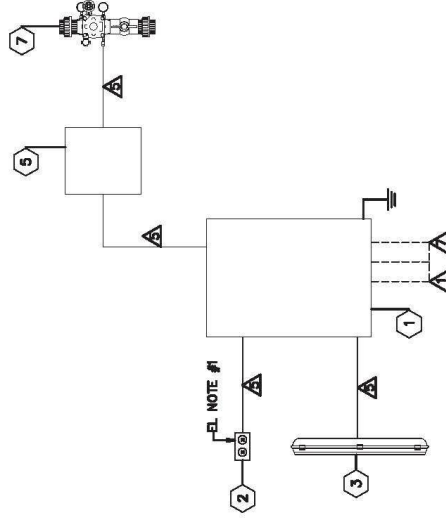

ELECTRICAL SCHEMATIC
 SCALE: N.T.S.